

(160 bar)	12 volt	24 volt
Pumpe - Motoreinheit	245 A	125 A
Magnet (Hydr.aggregat)	4,2 A	2,1 A
Magnet (El. Schlauchbr.ventil)	1,5 A	0,75 A
Magnetventil	1,5 A	0,85 A
Kabelfläche:		
Steuerkable	1,5 mm ²	1,5 mm ²
Stromversorgung 0-8 m	35 mm ²	35 mm ²
Stromversorgung 8-15 m	50 mm ²	35 mm ²
Stromversorgung <15 m	-	50 mm ²
Stromquelle:		
Min. Kapazität	170 Ah	180 Ah
Min. Spannung	9 Volt	18 Volt

Belastungsdiagramm

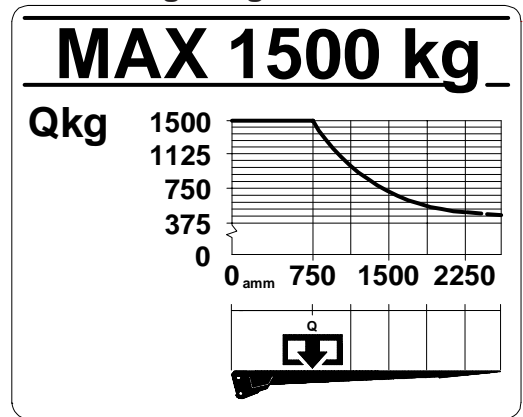

Montagemaße (mm)

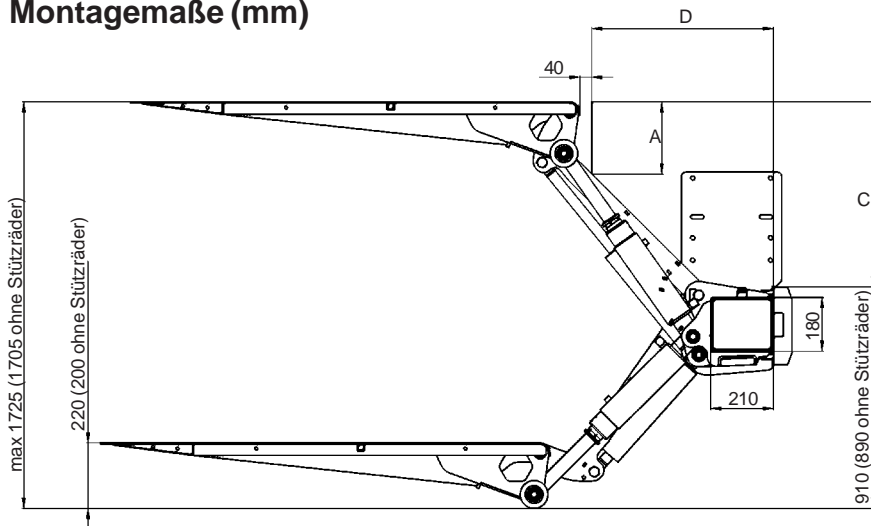

C	A	D
815	253	749
765	230	813
715	208	868
665	185	916
615	166	958
565	149	994
515	133	1026
465	119	1054
400	103	1085

